

2014 National Electrical Code Revision Highlights

Chad Kennedy, P.E.
Manager, Industry Standards



2014 NEC Facts

- 3,745 Proposals
- 1,625 Comments
- 4 New Articles (393, 646, 728, 750)
- 19 Code Making Panels
- 473 Volunteer Code Making Panel Members
- NFPA Annual Meeting, June 2013
- 2014 NEC Published, September 2013

New Articles

Article 393 - Low Voltage Suspended Ceiling Power Distribution Systems

- A system that serves as a support for a finished ceiling surface and consists of a busbar and busbar support system to distribute power to utilization equipment supplied by a Class 2 power supply.
- Listed utilization equipment - maximum of 30 volts ac (42.4 volts peak) or 60 volts dc and limited to Class 2 power levels
- Indoor Only

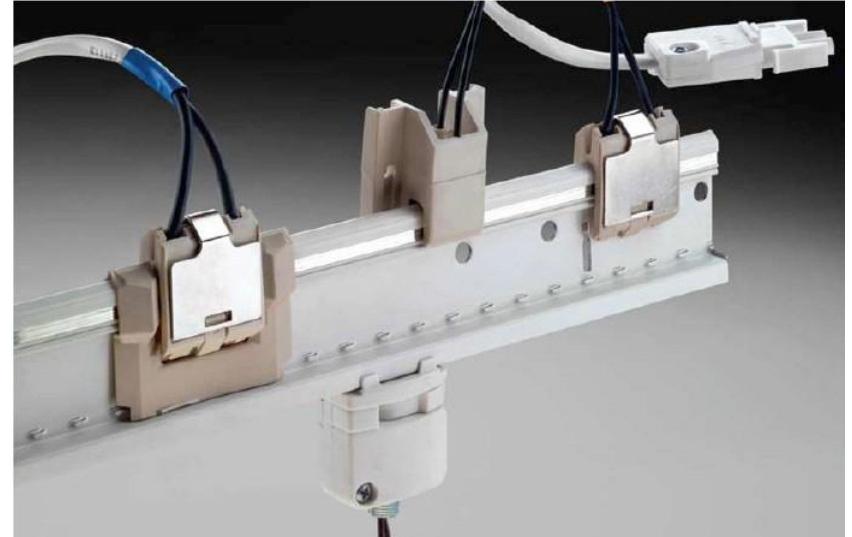

Article 646 - Modular Data Systems

Modular Data Center (MDC).

Prefabricated units rated 600 volts or less, consisting of an outer enclosure housing multiple racks of information technology equipment (ITE) (e.g. servers) and various support equipment such as electrical service and distribution equipment, HVAC systems and the like.

IFN: Some configurations may have the support equipment housed in a separate enclosure.



Article 728 Fire Resistive Cable Systems

- Covers the installation of fire resistive cables, conductors and other system components used for survivability of critical circuits to provide continued operation during a specified time under fire conditions
- Ability to function during a fire depends upon proper installation and there are differences between system types
- Examples are: conduit, conduit supports, type of couplings, vertical supports and boxes and splices.

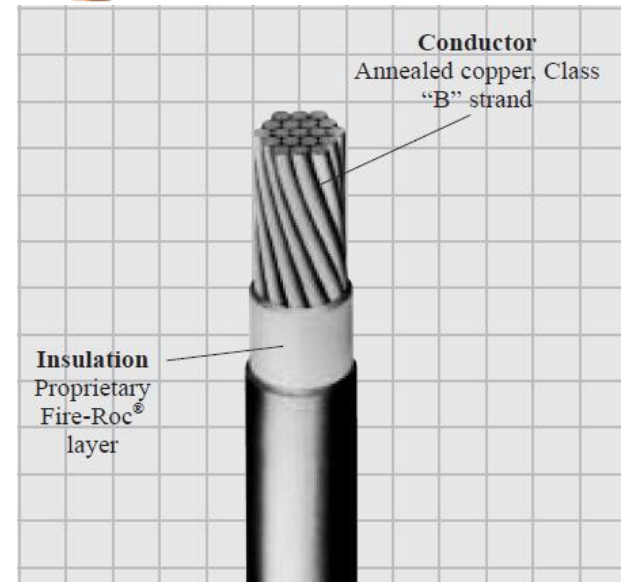
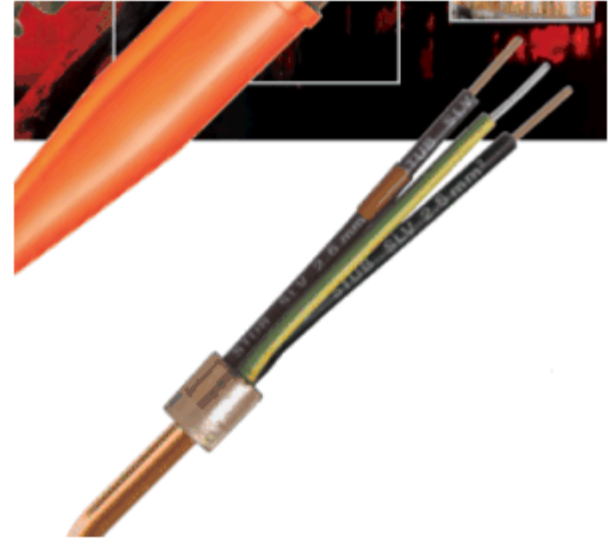

Article 750 Energy Management Systems

- Article proposed by the “Smart Grid Task Group” appointed by the Technical Correlating Committee
- Energy Management has become common place in today’s electrical infrastructure - **control of utilization equipment, energy storage and power production**
- Restricting the control of the system by the energy management system becomes critical to ensure safety (Example: load shedding for an alternate power source for fire pumps and emergency systems)



2014 NEC Code Wide Proposals

Increasing 600 V requirements to 1000 V

- Technological advancements in Wind and PV Systems are driving the operating voltages for these systems above 600 V
- Existing Over 600 V NEC rules are burdensome
- Equipment is already being Listed above 600 V
 - Wire rated at 2000 V
 - Switches rated for 1000 V
 - Inverters Listed to operate at 1000 V
- NEC rules for Grounding and Surge Protection already recognized a 1000 V break instead of 600 V
- Working Space requirements in Article 110 were not revised



110.21(B) Field-Applied Hazard Markings

Caution, warning, or danger signs or labels required must meet the following requirements.

1. The marking shall adequately warn of the hazard using effective words and/or colors and/or symbols.

2. The label shall be permanently affixed to the equipment or wiring method and shall not be hand written.

Exception to 2: Portions of labels or markings that are variable or could be subject to changes, shall be permitted to be hand written and shall be legible.

3. The label shall be of sufficient durability to withstand the environment involved.



110.21(B) Field-Applied Markings

- **Informational Note added referencing ANSI Z535.4-2011**
- **Provides guidelines for the design and durability of safety signs and labels**
- **Includes specific information related to suitable font sizes, colors, various symbols and location requirements for labels.**



110.25 Lockable Disconnecting Means

Usability Task Group Appointed by the NEC Correlating Committee

- Identified need for common set of requirements throughout the code
- Applies where the disconnect is required lockable in the open position
- Provisions for locking shall remain in place with or without the lock installed.
- Correlating proposals made throughout the code

Exception for cord and plug connected equipment



Not OK

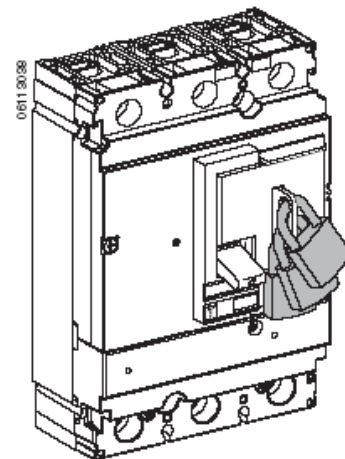

OK

Change Proposals by Section

100 Definitions

Readily Accessible

- Required where quick access is needed
- Includes operation, service, and inspection activities
- Installations which require the use of tools or present obstacles to access are not permitted.



100 Definitions

Adjustable Speed Drive. Power conversion equipment that provides a means of adjusting the speed of an electric motor.

Informational Note: A variable frequency drive is one type of electronic adjustable speed drive that controls the rotational speed of an alternating current electric motor by controlling the frequency and voltage of the electrical power supplied to the motor.



100 Definitions

Adjustable Speed Drive System. A combination of an adjustable speed drive, its associated motor(s), and auxiliary equipment.



100 Definitions

Coordination (Selective). Localization of an overcurrent condition to restrict outages to the circuit or equipment affected, accomplished by the selection and installation of overcurrent protective devices and their ratings or settings for full range of available overcurrents, from overload to the maximum available fault current, and for the full range of overcurrent protective device opening times associated with those overcurrents.

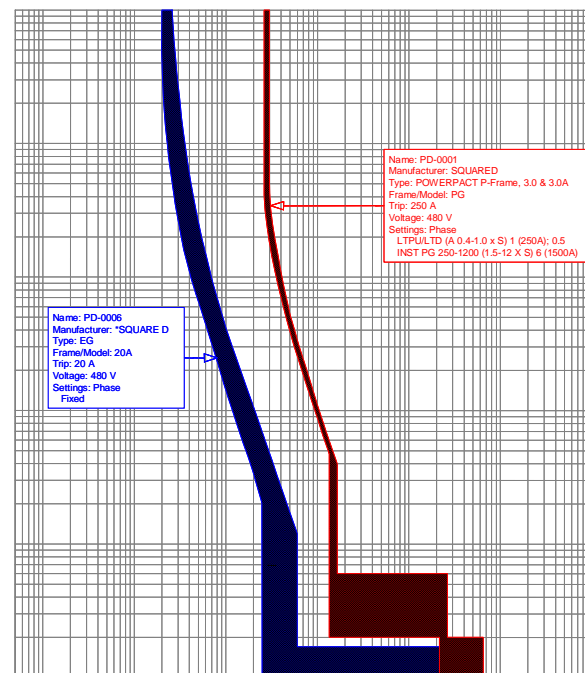

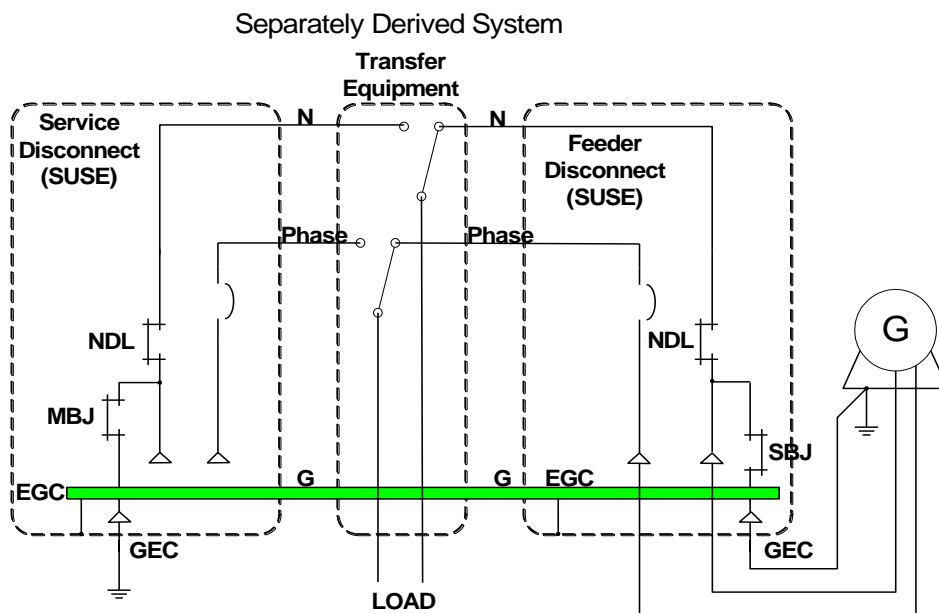

100 Definitions



Separately Derived System. An electrical source, other than a service, having no direct connection(s) to circuit conductors of any other electrical source other than those established by grounding and bonding connections.

110.16 Arc-Flash Hazard Marking

- Field marking or **Factory marking** permitted
- Recognizes that many products have marking from the manufacturer which accomplishes this requirement

 DANGER	
	<p>HAZARD OF ELECTRIC SHOCK, EXPLOSION, OR ARC FLASH</p> <ul style="list-style-type: none">• Apply appropriate personal protective equipment (PPE) and follow safe electrical work practices. See NFPA 70E
<ul style="list-style-type: none">• This equipment must only be installed and serviced by qualified electrical personnel.• Turn off all power supplying this equipment before working on or inside equipment.• Always use a properly rated voltage sensing device to confirm power is off.• Replace all devices, doors and covers before turning on power to this equipment.	
<p>Failure to follow these instructions will result in death or serious injury.</p>	

110.24 - Available Fault Current

- (A) Service equipment to be marked in the field with the maximum available fault current.
 - Excludes Dwellings
 - Must include date the fault current calculation was performed
 - Sufficient durability to withstand the environment
- (B) Modifications
 - Must verify or recalculate the value
 - Adjust marking if necessary

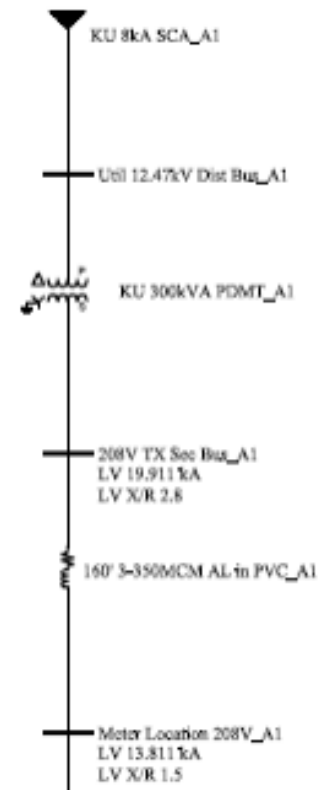

(New) Informational Note: The available fault current marking(s) addressed in 110.24 are related to required short-circuit current ratings of equipment. NFPA 70E-2012, Standard for Electrical Safety in the Workplace, provides assistance in determining severity of potential exposure, planning safe work practices, and selecting personal protective equipment.

110.26(C)(3) – Personnel Doors

(3) Where there is equipment rated **800A** or greater and there are doors that are within 25' of the nearest edge of the working space – the door must have **panic hardware** and must open outward

Rules for two working space entrances in 110.26(C)(2) are **unchanged** (equipment rated 1200A or greater and the equipment is over 6 feet wide)

Equipment 800A or greater

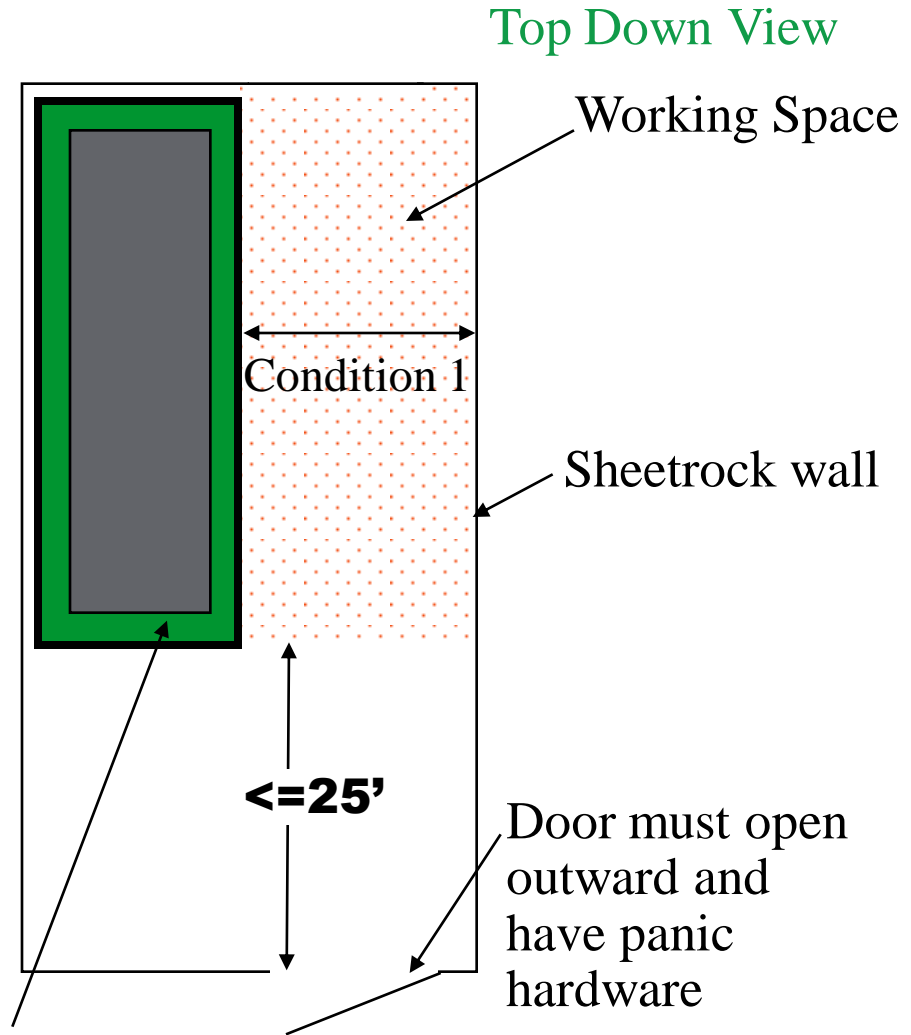

110.26(C)(3) – Personnel Doors

- Revision to use the term “panic hardware” versus “... be equipped with panic bars, pressure plates, or other devices that are normally latched but open under simple pressure. Must be listed
- Drives consistency with applicable Building Codes which only use this term
- Similar revision 110.33(A)(3) for over 600 V equipment



110.26(E) – Dedicated Equipment Space (2) – Outdoor

- Outdoor installations to meet dedicated equipment space requirements
- Space equal to width and depth of equipment and extending from grade to a height of 6ft above the equipment
- No equipment outside of the electrical installation allowed in this space

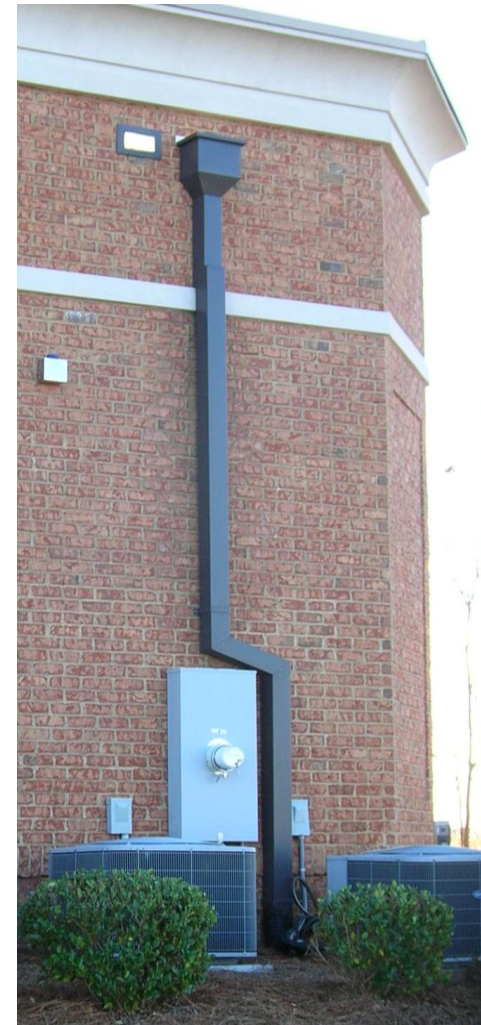

210.8(A) – GFCI (Dwellings)

(9) – Bathtubs and Shower Stalls

- GFCI protection 125-volt, single-phase, 15- and 20-ampere receptacles within 6ft of a bathtub or shower stall
- Requirements cover installations where the bathtub or shower location is not a bathroom based on the definition in Article 100



210.8(A) – GFCI (Dwellings)

(10) - Laundry

- All 125-volt, single-phase, 15- and 20-ampere receptacles installed in the locations specified in 210.8(A)(1) through (10) shall have ground-fault circuit-interrupter protection for personnel.
- (10) Laundry Areas



210.8(B) – GFCI Additions (other than dwelling units)

- (8) Applies to all garages, service bays, and similar areas
- Removes allowance for areas without electrical diagnostic equipment, electrical hand tools, or portable lighting equipment
- Vehicle exhibition halls and showrooms are excluded



110.26(E) – Dedicated Equipment Space (2) – Outdoor

- Outdoor installations to meet dedicated equipment space requirements
- Space equal to width and depth of equipment and extending from grade to a height of 6ft above the equipment
- No equipment outside of the electrical installation allowed in this space

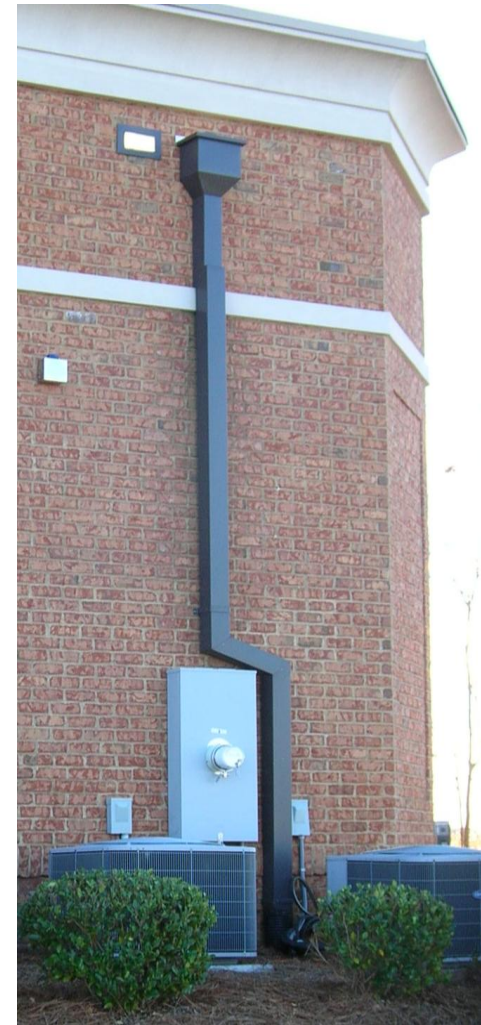

210.8(D) – GFCI (Dwellings)

Kitchen Dishwasher Branch Circuit

- GFCI protection shall be provided for outlets that supply dishwashers

Note: This is not a GFCI receptacle requirement.

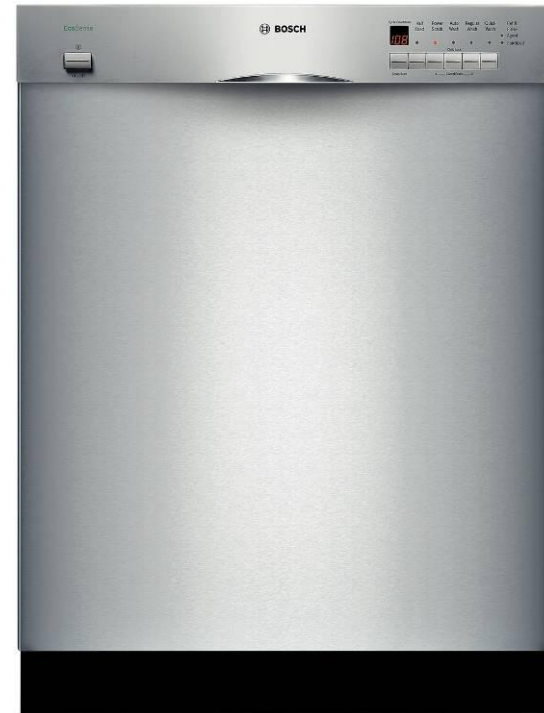

210.12 - AFCI

(A) – Dwelling Units

120V, 15A and 20A branch circuits that supply outlets or devices in dwelling units:

Kitchens, family rooms, dining rooms, living rooms, parlors, libraries, dens, bedrooms, sunrooms, recreation rooms, closets, hallways, **laundry areas**, or similar rooms



210.12 - AFCI

(C) – Dormitory Units

120V, 15A and 20A branch circuits that supply outlets in dormitory unit:

Bedrooms, living rooms, hallways, closets, and similar rooms



210.12(A) – AFCI (Dwellings)

Six Options now permitted for AFCI protection

1. Combination type arc-fault circuit interrupter, installed to provide protection of the entire branch circuit



2. Branch/feeder type AFCI installed at the origin of the branch circuit in combination with an outlet branch circuit type arc-fault circuit interrupter installed at the first outlet box on the branch circuit. (outlet box must be marked to indicate that it is the first outlet of the circuit)



210.12(A) – AFCI (Dwellings)

Six Options now permitted for AFCI protection (continued)

3. **Supplemental arc protection circuit breaker** installed at the origin of the branch circuit in combination with a listed outlet branch circuit type arc-fault circuit interrupter installed at the first outlet box on the branch circuit where all of the following conditions are met:



(a) Continuous branch circuit wiring from the branch breakers to the outlet branch circuit AFCI



(b) Maximum length of the branch circuit wiring to the first outlet must not exceed 50 ft for a 14 AWG or 70 ft for a 12 AWG

(c) First outlet box in the branch circuit shall be identified



210.12(A) – AFCI (Dwellings)

Six Options now permitted for AFCI protection (continued)

4. **Outlet branch circuit type arc-fault circuit interrupter installed at the first outlet box on the branch circuit in combination with a listed branch circuit overcurrent protective device** where all of the following conditions are met:
 - (a) Continuous branch circuit wiring from the branch circuit overcurrent protective device to the outlet branch circuit AFCI
 - (b) The maximum length of the branch circuit wiring to the first outlet must not exceed 50 ft for a 14 AWG or 70 ft for a 12 AWG
 - (c) The first outlet box in the branch circuit shall be identified
 - (d) The combination of the branch circuit overcurrent device and outlet branch circuit AFCI is identified as meeting the requirements for a "**System Combination**" type AFCI and is listed as such.



210.12(A) – AFCI (Dwellings)

Six Options now permitted for AFCI protection (continued)

5. Outlet branch circuit type arc-fault circuit interrupter installed at the first outlet box on the branch circuit in combination with ...
 - RMC, IMC, EMT, Type MC, or steel armored Type AC cables meeting the requirements of 250.118,
 - Metal wireways, metal auxiliary gutters and metal outlet and junction boxes are installed for the portion of the branch circuit between the branch-circuit overcurrent device and the first outlet

210.12(A) – AFCI (Dwellings)

Six Options now permitted for AFCI protection (continued)

6. Outlet branch circuit type arc-fault circuit interrupter installed at the first outlet box on the branch circuit in combination with ...
 - Listed metal or nonmetallic conduit or tubing or
 - Type MC Cable and
 - Encased in not less than 50mm (2 in.) of concrete for the portion of the branch circuit between the branch circuit overcurrent device and the first outlet

Exceptions (1) and (2) removed. Exception (3) for fire alarm systems retained

210.12(A) (5) & 210.12(A)(6)

Wiring from panel to first outlet must be installed in RMC, IMC, EMT, MC or steel jacketed AC cable.
Must also have metal outlet and junction boxes.

Also permits metallic and nonmetallic conduit or Tubing or MC cable where encased in 2" of concrete

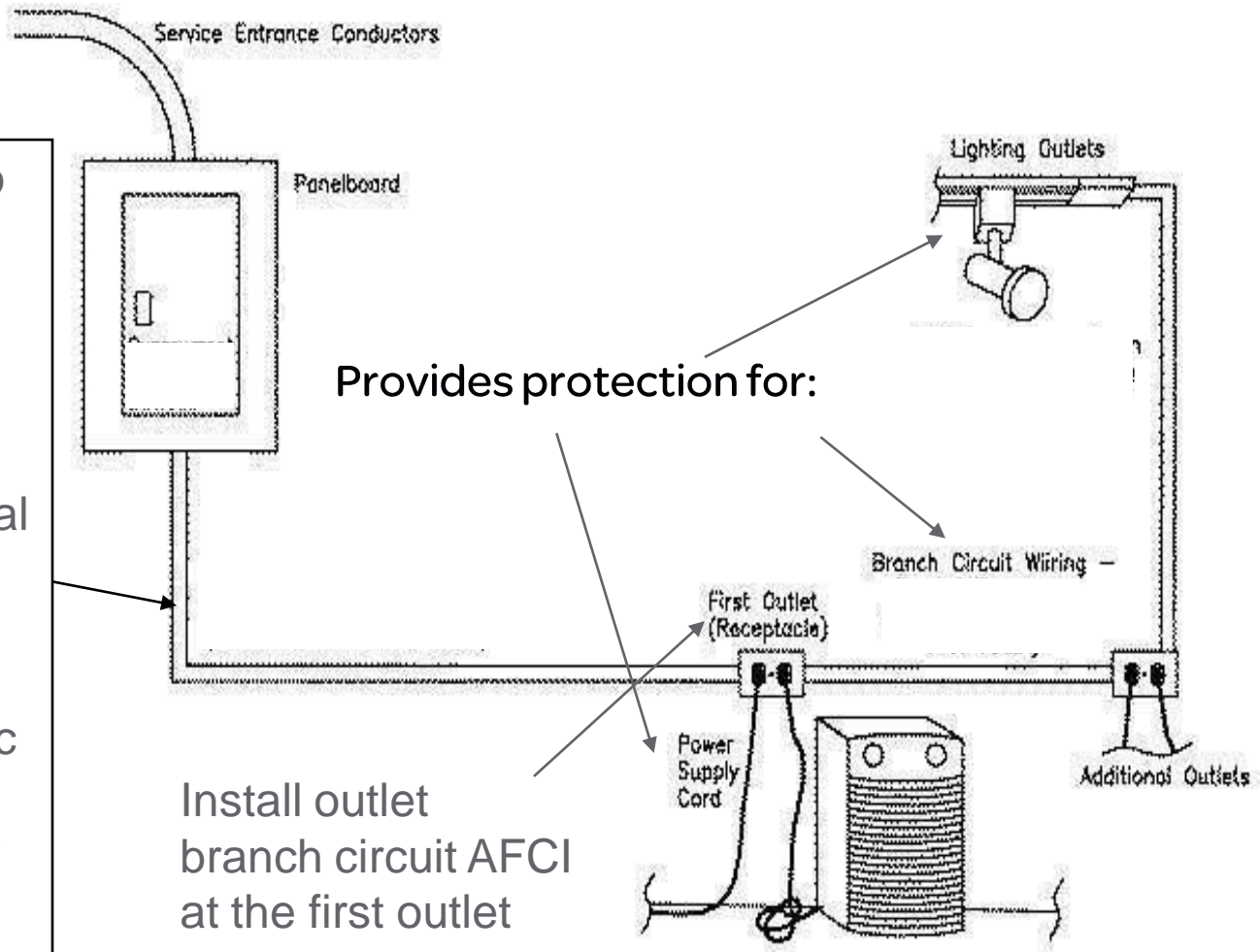

210.12(B) Ex. – Branch Circuit Extensions or Modifications – Dwelling Units

- AFCI is not required where:

- Extension does not exceed 6 ft
- No additional outlets or devices installed

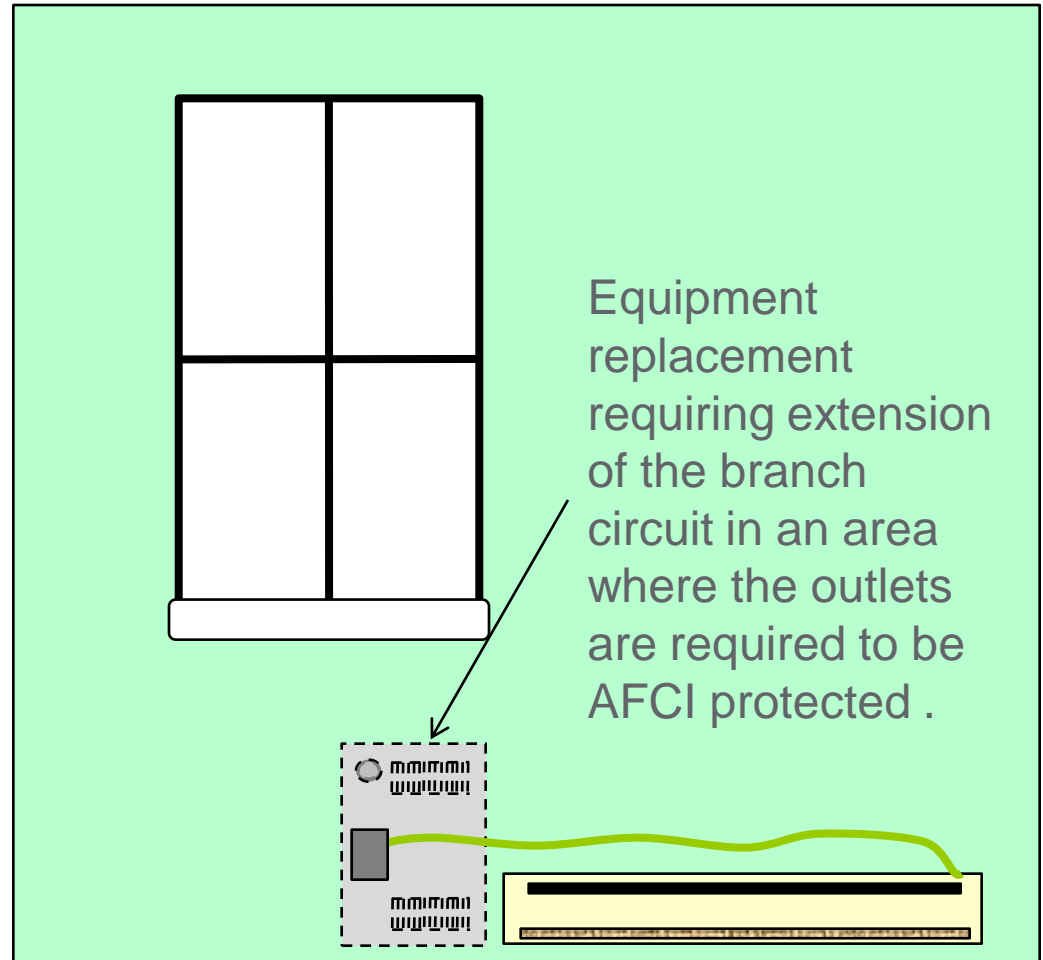

210.17 – Electric Vehicle Branch Circuit



- Outlet(s) installed for the purpose of charging electric vehicles shall be supplied by a separate branch circuit.
- **This circuit shall have no other outlets.**

210.52(E)(1) / (E)(2)– Outdoor Outlets (Dwellings)

- Outdoor receptacle outlets must be **readily accessible** from grade level
- Installed no higher than 6-1/2 ft above grade level
- At least one receptacle outlet at the front and rear of dwelling



210.52(G)(1) – Garages (one family dwellings)

- A receptacle outlet is required to be installed for each car space in an attached or detached garage with electric power
- The branch circuit supplying the receptacle(s) can only serve outlets in the garage



210.64 – Electrical Service Areas

- New section requires at least one 125 volt, single phase, 15 or 20 ampere rated receptacle outlet within 15 m (50 ft) of the electrical service equipment
- Exception for one and two family dwellings



220.12 Exception – Lighting Loads for Specified Occupancies

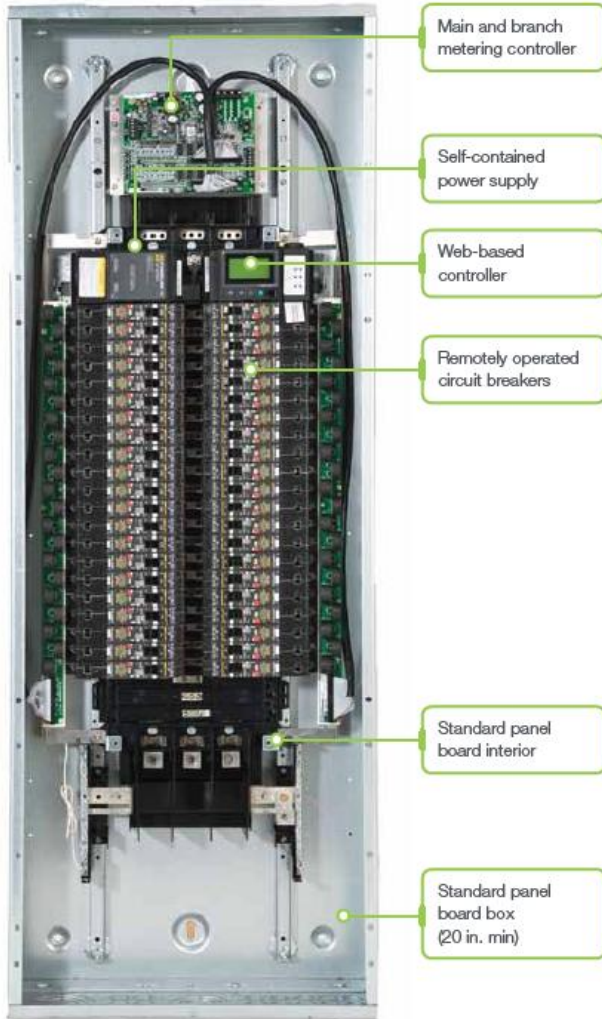

- New Exception allows lighting loads to be calculated using the adopted energy code
- Building must be designed and constructed to comply with the adopted energy code and meet the following:
 - Power monitoring system installed to provide lighting load data
 - Power monitoring system must have alarm(s) to alert the building owner/manager if the lighting load exceeds limits
 - Demand factors in 220.42 do not apply

240.87 – Arc Energy Reduction

- Required for circuit breakers that are rated or can be adjusted to 1200 A and above
- Documentation on the circuit breaker location and
- Reduced Clearing Time Method
 - Zone-selective interlocking or
 - Differential relaying or
 - Energy-reducing maintenance switching with local status indicator or
 - Energy-reducing active arc flash mitigation system or
 - An approved equivalent means

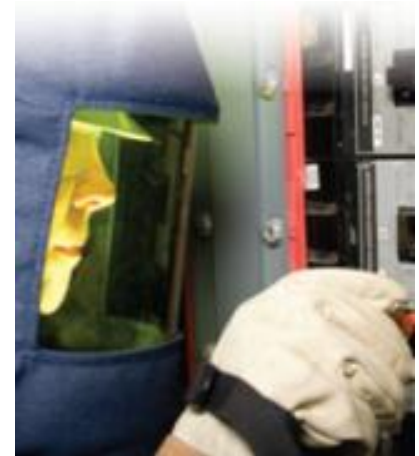

250.64(B) Grounding Electrode Installation

Securing and protection against physical damage

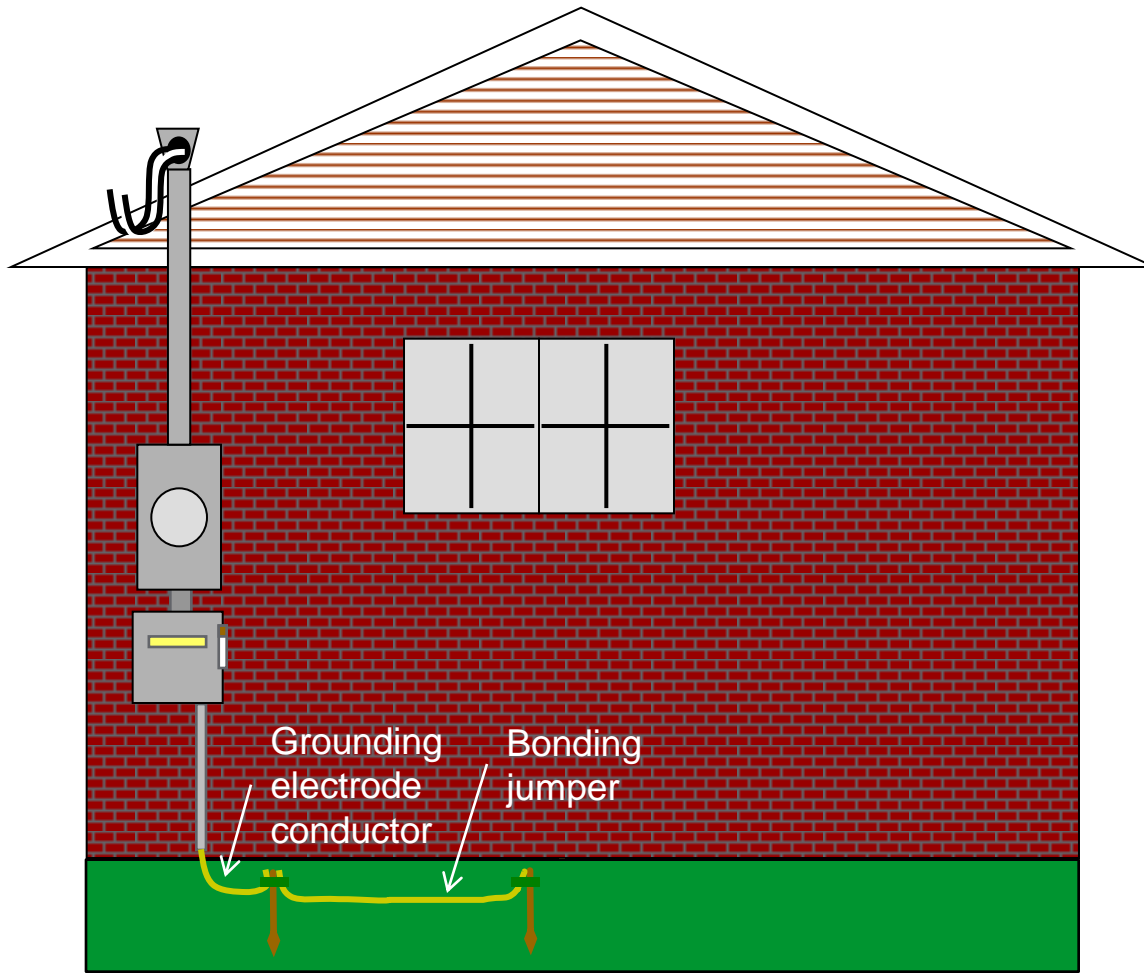

- Table 300.5 sets the minimum cover requirements
- Grounding electrode conductors and bonding jumpers **do not** have to meet the burial depth requirements for direct-buried conductors

250.68 – Grounding Electrode Connections

Concrete-encased electrode extension

- **Allows extension of the electrode to area above the concrete**
- **Must be accessible to allow for inspection of the connection**
- **Applies to conductor, reinforcing rod and bar types**

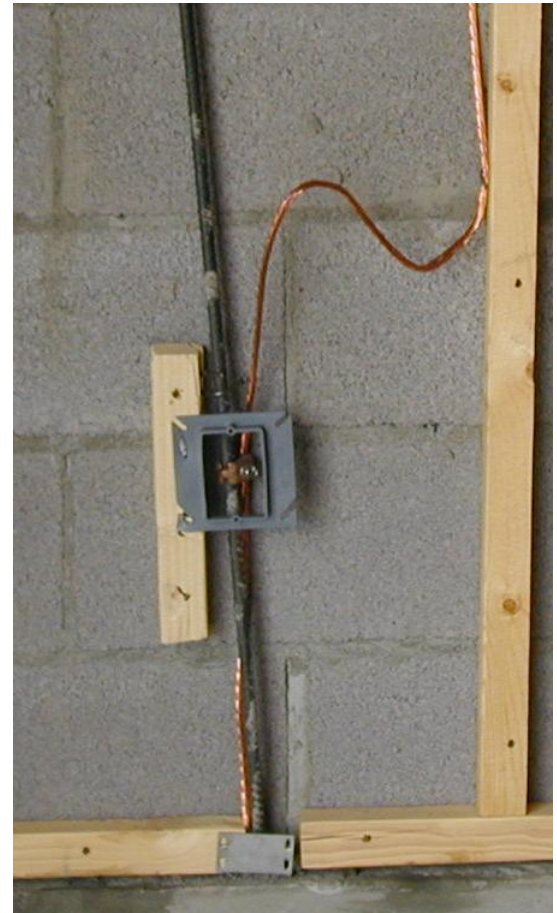

250.119 – Identification of Equipment Grounding Conductors



- New Exception No. 3 allows conductors with green insulation to be used as ungrounded signal conductors where installed between the output terminations of traffic signal control equipment and traffic signal indicating heads.
- Signaling circuits must include an equipment grounding/bonding conductor in accordance with 250.118.
- Wire type equipment grounding/bonding conductor must be bare, or have insulation or covering that is green with one or more yellow stripes.

250.130(C)(4) – Equipment Grounding Connections

Non-grounding receptacle replacement or branch circuit extensions

- Allows extension of a grounding electrode conductor from another branch circuit
- Branch circuits must originate in the same panelboard

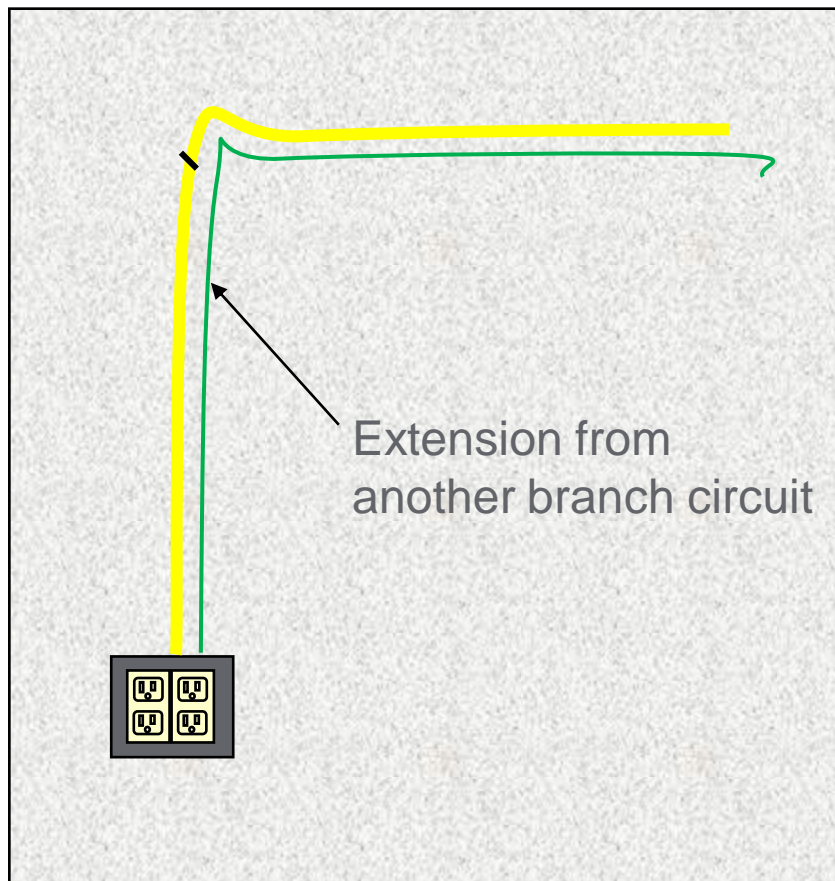

250.166 – DC Grounding Electrode Conductor

- Revision clarifies that the GEC for a dc system is not required to be larger than 3/0 copper or 250 kcmil aluminum
- Remainder of sizing requirements were unchanged



250.167 – DC Ground Fault Detection

- New section added for ground fault detection
- GF detection **required** for ungrounded systems and **permitted** for grounded systems
- Revision adds marking requirements to indicate the grounding type at the dc source or the first disconnecting means of the system



310.15(B)(3)(c) – Raceways and Cables Exposed to Sunlight on Rooftops

- Exposed to direct sunlight on rooftops
- Adjustments in Table 310.15(B)(3)(c) must be added to the outdoor temperature to determine the ambient temperature for the correction factors Table 310.15(B)(2)(a) or Table 310.15(B)(2)(b)
- Requirements now apply to all raceways – **not just circular**
- **Cables** are included

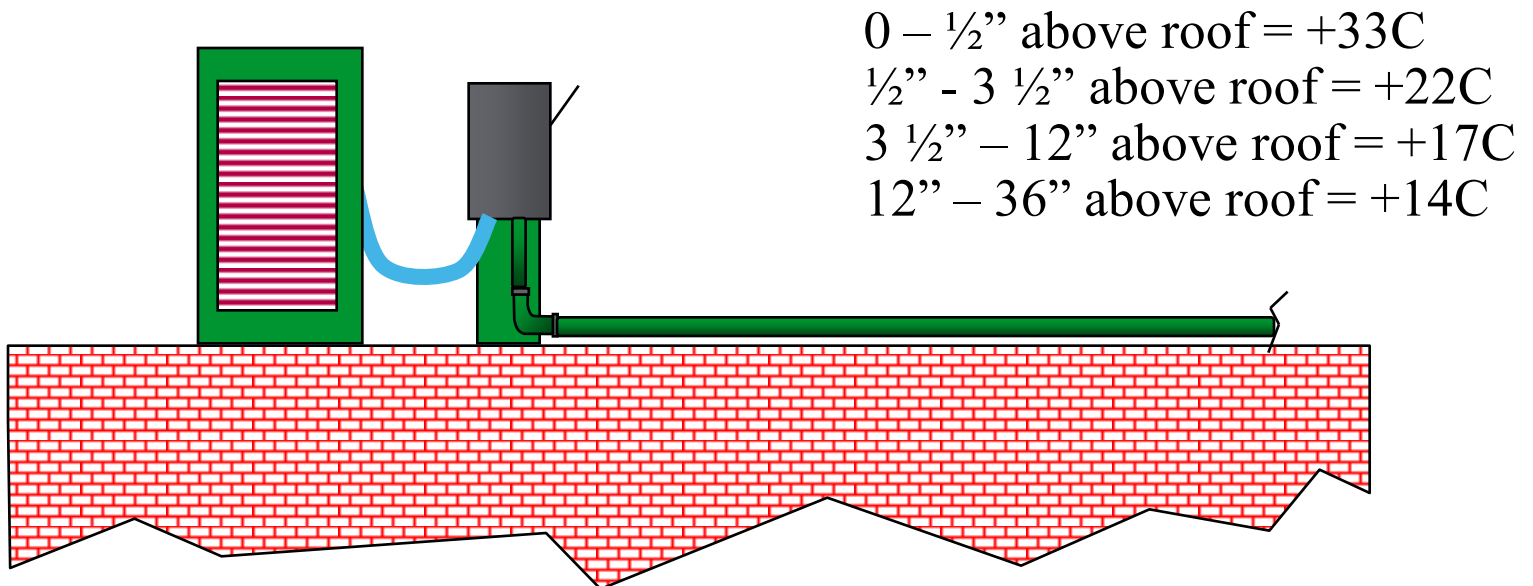

310.15(B)(3)(c) – Raceways and Cables Exposed to Sunlight on Rooftops

- New Exception for XHHW-2 insulated conductors (Thermoset)



310.15(B)(7) – 120/240 V, Single Phase, Services and Main Power Feeders (Dwellings)

- Table 310.15(B)(7) removed
- Service or Feeder ratings 100 through 400 A, an **adjustment factor of 0.83** of the service or feeder ampere rating can be used to determine the size of the ungrounded conductors where supplying the entire load
- Grounded conductor can be smaller than the ungrounded conductors, see 215.2, 220.61, and 230.42
- Other correction or adjustment factors applicable to the conductor installation apply
- New example added to Annex D



310.15(B)(7) – 120/240 V, Single Phase, Services and Main Power Feeders (Dwellings)

6-49a Log #CP604 NEC-P06
(310.15(B)(7))

Final Action: Accept

Submitter: Code-Making Panel 6,

Recommendation: Delete Table 310.15(B)(7) and replace 310.15(B)(7) with the following:

(7) 120/240 Volt, Single-Phase Dwelling Services and Feeders. For service and feeder conductors of 120/240-volt, single-phase, individual dwelling unit one-family, two-family, and multifamily service ratings from 100 through 400 amperes, an adjustment factor of 0.83 of the service ampere rating shall be permitted to be used to determine the size of the ungrounded conductors. The grounded conductor shall be permitted to be smaller than the ungrounded conductors, provided that the requirements of 215.2, 220.61, and 230.42 are met.

Informational No. 1: The conductor ampacity may require other correction or adjustment factors applicable to the conductor installation.

Informational No. 2: See example DXXX in Annex D.

Substantiation: It was determined that during the 1956 Proceedings of the Sixteenth NFPA Annual Meeting that 84 percent was used to establish the aluminum residential service conductor size. However, if the panel used 84 percent in the changed language, it would have resulted in larger sizes for some of the conductors, compared to the sizes in the 2011 NEC. Since the panel had no technical substantiation to justify these changes, 83 percent was used to maintain consistency with the sizes in the 2011 Table 310.15(B)(7).

In order to address the various proposals submitted suggesting changes to 310.15(B)(7), the panel analyzed the existing language and determined that the conductor sizes in Table 310.15(B)(7) are equivalent to those that would be used if a 0.83 multiplier was applied to each service ampere rating. The resulting conductor size will be the same as existing text in Table 310.15(B)(7), if the same conductor types and installation conditions are applied.

The informational note was added to make it clear that adjustment and correction factors apply depending on conditions of use. This action no longer requires the definition of a "main power feeder" in 310.15(B)(7).

314.27(A)(2) – Boxes at Luminaire or Lampholder Outlets

Ceiling Outlets

- Standard ceiling outlet boxes for luminaire or lampholder use must support 50 lbs
- Luminaires exceeding 50 lbs and supported from the ceiling box must use a box which is marked with the maximum weight allowed.



334.40(B) – Devices of Insulating Material

- Removes the requirement for a box when installing self-contained switches, self-contained receptacles, or NM interconnectors
- Applies to exposed cable wiring and concealed repair wiring
- Devices must be listed



368.2 – Busway

- Revision to the busway definition clarifies the use of the busway enclosure for grounding and bonding.
- Busway. A raceway consisting of a grounded metal enclosure containing factory-mounted, bare or insulated conductors, which are usually copper aluminum bars, rods, or tubes.

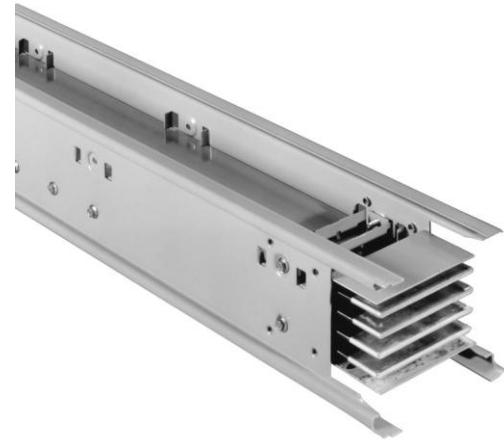

386.120 – Surface Metal Raceways

- New marking requirement for each length of raceway
- Manufacturer's name or unique identification
- Similar revision for nonmetallic surface raceways in 388.120

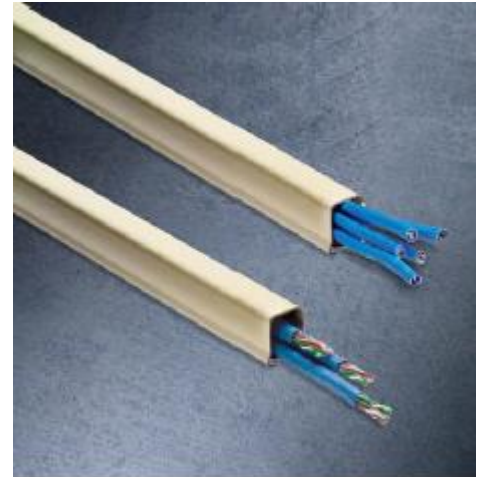

400.7(A)(11) Flexible Cords and Cables

- Permits flexible cord connection between a receptacle outlet and a inlet.
- Inlet is permanently wired using a standard wiring method to a single receptacle outlet.
- Wall mounting of flat screen televisions or monitors is a common application



404.2(C) Switches Controlling Lighting Loads

Grounded circuit conductor shall be provided at the switch location

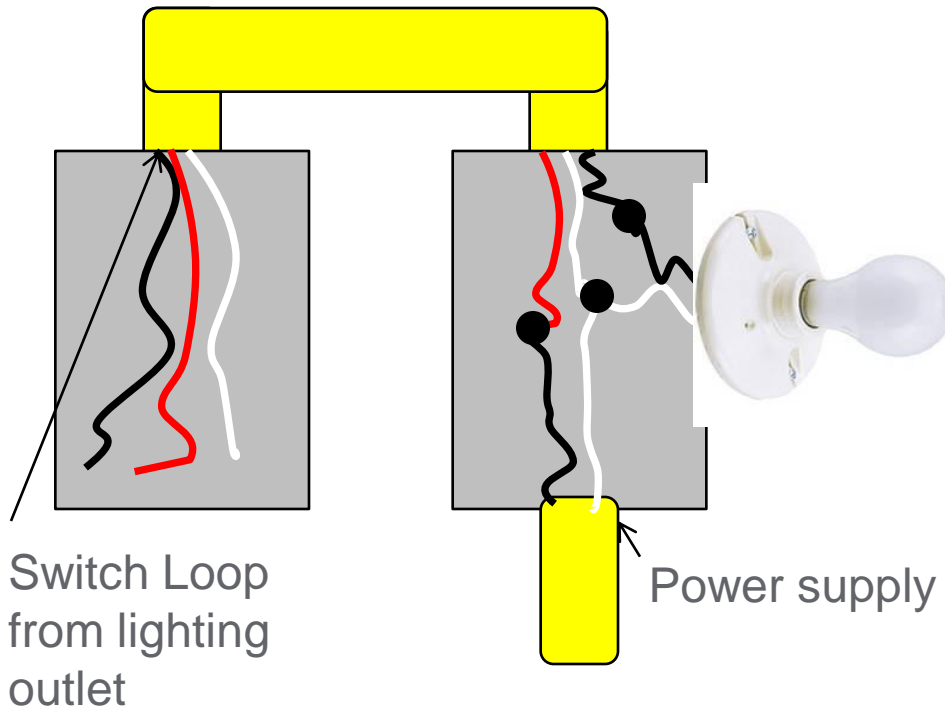

Raceway installations exempt if sized to accommodate extension of the grounded conductor

Not required if the box enclosing the switch is accessible for the installation of additional or replacement cable without removing finish materials

Not required for snap switches with integral enclosures per 300.12(E)

404.2(C) Switches Controlling Lighting Loads

A grounded circuit conductor must be provided at the switch location unless one of the following apply:

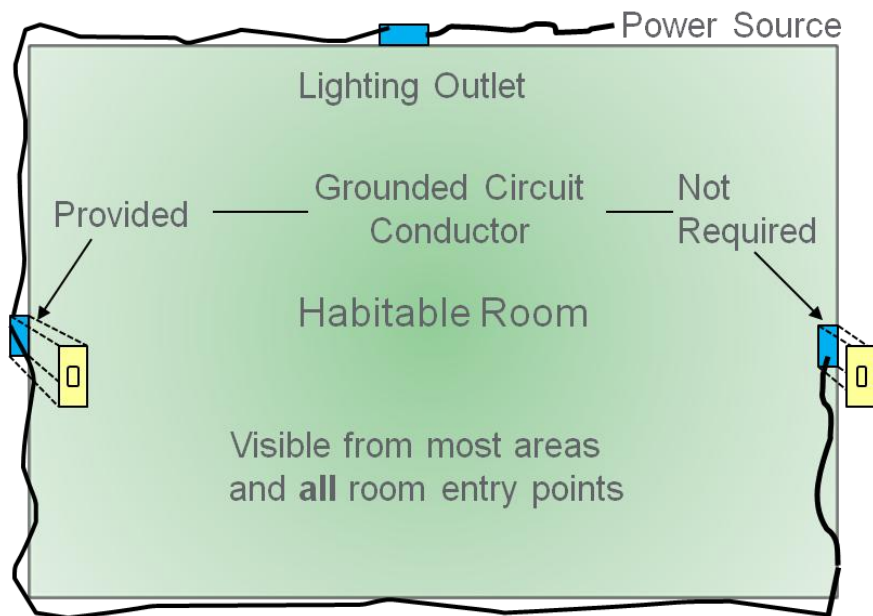

- Raceway sized to accommodate a grounded conductor
- Box enclosing the switch is accessible without removing finish materials
- Snap switches with integral enclosures per 300.12(E)
- Switch does not serve a habitable room or bathroom
- Multiple switch locations control the same lighting load and the entire floor area is visible from one or more switches
- Area lighting is automatically controlled
- Switch controls a receptacle load

406.9(B)(1) Receptacles – Wet Locations

- Expands the “extra duty” cover requirement to all wet location receptacle locations **not just those supported from grade**
- Similar revision to 590.4(D)(2)- clarifies the “extra duty” requirements apply to all wet location temporary installations, **including dwellings**



408.3(E)(2) DC Bus Arrangement

Direct-current ungrounded buses shall be permitted to be in any order. Arrangement of dc buses shall be field marked as to polarity, grounding system, and nominal voltage.

408.3(F)(3) High-Impedance Grounded Neutral AC System

- Field marking for switchboard, switchgear, or panelboard per 250.36
- Required text:

CAUTION: HIGH-IMPEDANCE GROUND NEUTRAL AC SYSTEM OPERATING — _____ VOLTS BETWEEN CONDUCTORS AND MAY OPERATE — _____ VOLTS TO GROUND FOR INDEFINITE PERIODS UNDER FAULT CONDITIONS

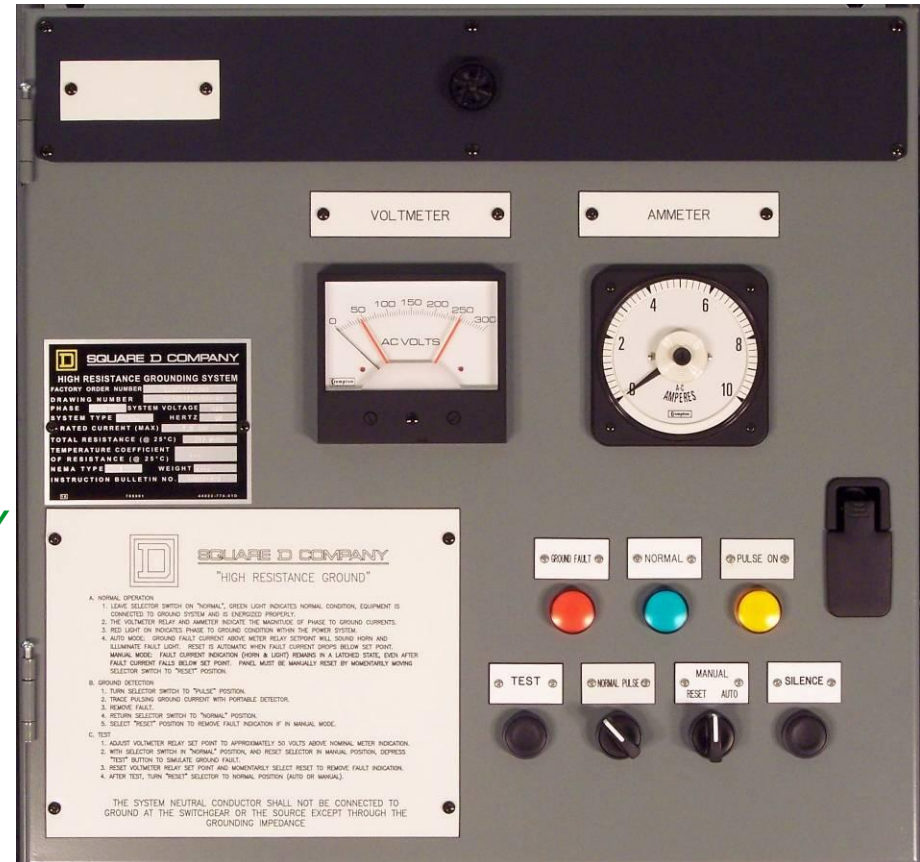

408.3(F)(4) Ungrounded DC Systems

- Field marking for switchboard, switchgear, or panelboard per 250.169
- Required text:

CAUTION: CAUTION: UNGROUNDED
DC SYSTEM OPERATING — _____
VOLTS BETWEEN CONDUCTORS

408.3(F)(5) Resistively Grounded DC Systems

- Field marking for switchboard, switchgear, or panelboard
- Required text:

CAUTION: DC SYSTEM OPERATING
— _____ VOLTS BETWEEN
CONDUCTORS AND MAY OPERATE
— _____ VOLTS TO GROUND FOR
INDEFINITE PERIODS UNDER FAULT
CONDITIONS

410.6 Listing Required – Luminaires, Lampholders, and Lamps

- Expands the listing requirements to retrofit kits for lampholders and luminaires
- Retrofit Kit definition added to Article 100 which provides clarity and distinguishes retrofit kits from re-lamping activities (no field conversion of the utilization equipment)



410.10 Luminaires Installed in or Under Roof Decking

- Exposed or concealed locations under metal-corrugated sheet roof decking
- Must be installed at least 1-1/2 inches below the lowest surface of the roof decking
- Aligns with similar requirements for cables, raceway and boxes in 300.4(E)

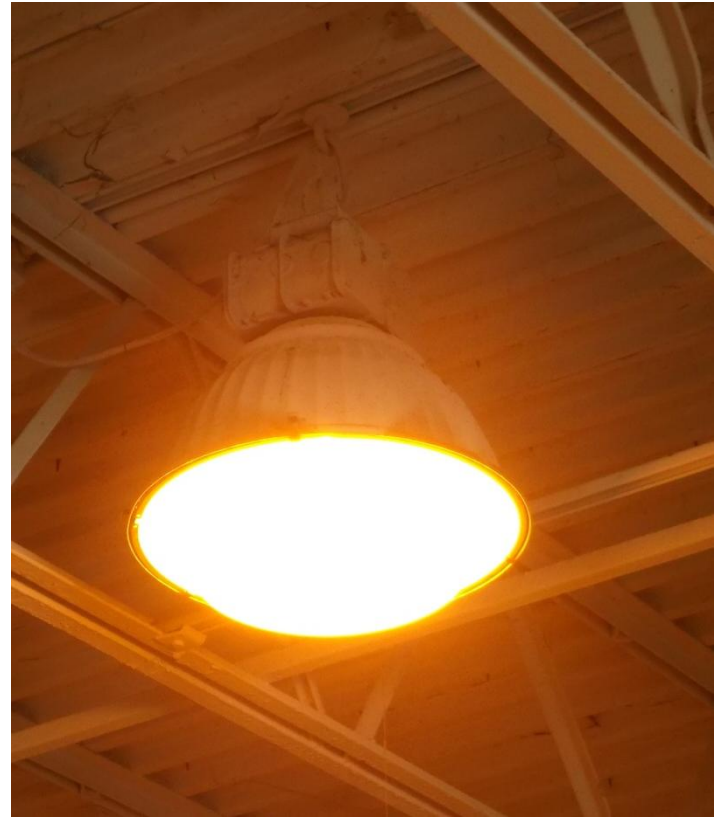

422.23 Tire Inflation and Automotive Vacuum Machines

Tire inflation machines and automotive vacuum machines provided for public use shall be protected by a ground-fault circuit interrupter.



430.130(A) Single Motor Circuits Containing Power Conversion Equipment

Branch circuit short circuit (SC) and ground fault protection (GFP) must be comply with the following:

- (1) Rating and type of protection per 430.52 (C) (1), (3), (5) or (6) using the full load current rating of the motor load as determined by 430.6.
- (2) Maximum SC and GFP ratings provided in the manufacturers instructions with the power conversion equipment or are otherwise marked on the equipment can not be exceeded even if higher values are permitted in 430.130 (A) (1).
- (3) A self-protected combination controller is permitted where specifically identified in the manufacturer's instructions with the power conversion equipment or marked on the equipment.



445.11 Marking

Revision requires marking when the neutral of a generator is bonded to the generator frame

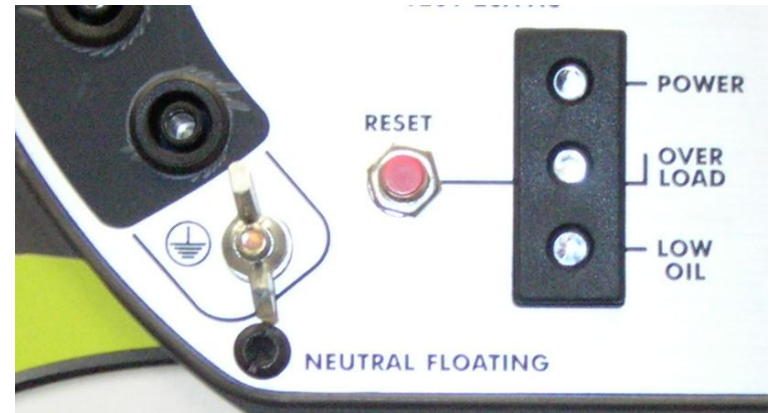

445.11 Marking

Generator nameplate marking revised to differentiate generators over 15 kW

- Power factor
- Impedance
- Insulation class
- Time ratings



ELLIOTT POWER SYSTEMS, INC. 58 Elliott Power Dr. Lexington, TN 38351

MODEL NO.	50 RD	SERIAL NO.	BW04J748		
DUTY	STANDBY	FUEL	DIESEL	DRY WT. (APPROX.)	4039 LBS.
P. F.	0.8	1.0	R.P.M.	1800	60
	3 Ø	1 Ø		3 Ø	1 Ø
KW/KVA	50/62	30/30	VOLTS	208/240/480	120/240
AMB.	40 °C, @300 FT	AMPS	174/150/75	125/125	
REMARKS	ISUZU 4BG1		EMI 251914-00		
	MTG 24		277/480V 3PH		

EGSA ELECTRICAL GENERATING SYSTEMS ASSOCIATION MEMBER
MADE IN U.S.A. 26452501 REV #1

445.18 Generator Disconnect

Revision removes generator disconnect requirements for:

- Portable generators that are cord and plug connected or
- The driving means for the generator can be readily shut down, rendered incapable of restarting and is lockable in the OFF position in accordance with 110.25 and
- The generator is not arranged to operate in parallel with another generator or other source of voltage.



445.20 GFCI Protection for Receptacles on Portable Generators (<15 kW)

- All 125-volt, single-phase, 15- and 20-ampere receptacle outlets, that are a part of a 15 kW or smaller, portable generator, either shall have...
 - GFCI integral to the generator or receptacle or
 - Arranged so that these receptacles are not be available for use when the 125/250 volt locking receptacle is in use
- Generators without a 125/250 volt locking type receptacle are exempt
- Listed cord sets or devices incorporating listed GFCI protection identified for portable are permitted for installations of generators manufactured or re-manufactured prior to January 1, 2015 (TIA 70-14-2)



450.10(A) Dry-Type Transformer Enclosures

- Revision clarifies the installation of grounding and bonding connections
- Requires the installation of a terminal bar secured to inside the transformer enclosure and bonded in accordance with 250.12. The terminal bar shall not be installed on or over any vented portion of the enclosure
- An exception for transformers supplied with integral leads as the connection means



450.11 Marking - Transformers

- Revision clarifies the marking requirements by using subdivisions and a list format for the general rules
- New subdivision (B) for transformer source marking permits a transformer to be **supplied** at the marked secondary voltage provided the installation is in accordance with the manufacturers' instructions



480.6 DC Disconnect Methods

- Requirements are divided into subdivisions (A) thru (D)
- Revision clarifies that a disconnect is required for systems with a **nominal voltage** over 50 volts
- Controls to activate the disconnecting means of the system are **permitted to be remote** where the disconnecting means is capable of being locked in the open position and the location of the controls is field marked on the disconnecting means
- For DC busway systems, the disconnect is permitted to be in the busway.
- Disconnect must be labeled, on or adjacent, with the **maximum available short circuit current**. If a disconnect is not provided, the label must be in a conspicuous location near the battery.



480.9(C) Spaces About Battery Systems

- Battery systems working space must comply with 110.27
- Working space measured from the edge of the battery cabinet, racks, or trays
- Battery racks, a minimum clearance of 1 in. is required between a cell container and any wall or structure on the side not requiring access for maintenance.
- Battery stands are permitted to contact adjacent walls or structures provided that the battery shelf has a free air space for not less than **90 percent of its length**
- IFN: Additional space may be needed to accommodate battery hoisting equipment, tray removal, or spill containment.



480.9(G) Illumination

- Required for battery system working spaces
- Lighting outlets shall not be controlled by automatic means only.
- Additional lighting outlets shall not be required where the work space is illuminated by an adjacent light source.
- Location of luminaires shall not:
 - (1) expose personnel to energized battery components while when performing maintenance on the luminaires in the battery space; or
 - (2) create a hazard to the battery upon failure of the luminaire.



490.48 Substations



Requirements for substations were moved from 225.70 to 490.48
Scope alignment – substations are installed both indoors and outdoors

490.48(A) Documentation

- Documentation of the design by a qualified professional engineer must be available
- Must consider
 - (1) General.
 - (a) Types of enclosures
 - (b) Rooms and spaces
 - (c) Supporting and securing electric equipment
 - (d) Exits
 - (e) Fire-extinguishing equipment
 - (2) Protective Grounding.
 - (3) Guarding Live Parts.
 - (4) Transformers and Regulators.
 - (5) Conductors.
 - (6) Circuit Breakers, Switches, and Fuses.
 - (7) Switchgear Assemblies.
 - (8) Metal-Enclosed Bus.
 - (9) Surge Arresters.

490.48(C) Diagram

Single-line diagram

- Permanent
- Readily visible location within same room or area
- Includes interlocks, isolation means, and possible sources under normal and emergency conditions
- Marking on the equipment shall align with the diagram
- Exception for single cubicle or metal enclosed unit substation containing only one set of high-voltage devices

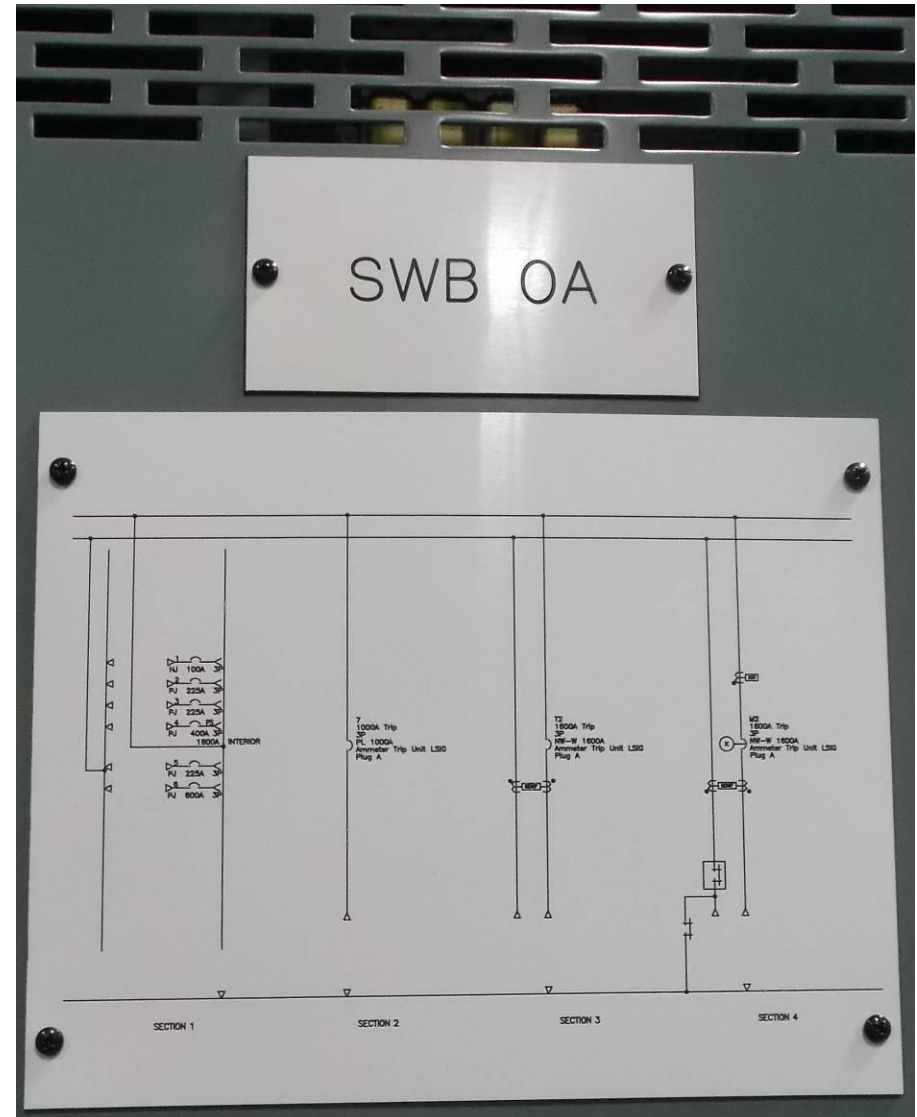

Article 517 Healthcare Facilities



- Revisions align NEC requirements with NFPA 99
- Clarify the use of the term “Emergency” and where the requirements of Article 700 apply
- Correlation of EES overcurrent device coordination requirements

517.16 Receptacles with Insulated Grounding Terminals

- Revision permits the use of receptacles with insulated ground where not installed in a patient care vicinity
- Aligns NEC requirements with NFPA 99



517.18(B) Patient Bed Location Receptacles

- This proposed change increases the minimum number of receptacles required from four to eight.
- Aligns with NFPA 99 relative to the increases in quantity of receptacles and normal care patient bed locations.



517.18(C) Receptacles in General Care Pediatric Locations

- Receptacles in patient rooms, bathrooms, playrooms, and activity rooms, other than nurseries, must be tamper-resistant or employ a tamper-resistant cover.
- Aligns NEC requirements with NFPA 99



517.19(B) Patient Bed Location Receptacles – Critical Care

- Section 517.19 addresses critical care patient bed locations. This proposed revision in subdivision (B) changes the required minimum number of receptacles from six to fourteen.
- List item (2) in this section was revised by removing the term “emergency system” and replacing it with the term “critical branch.”
- Aligns with changes in NFPA 99-2012



517.19(C) Operating Room Receptacles

- The minimum number of receptacles required in an operating room is thirty-six of which at least twelve of the thirty-six receptacles must be connected to either the normal system branch or the critical system branch.
- The grounding terminal of these receptacles must be connected to the reference grounding point by means of an insulated copper equipment grounding conductor.



BERKTHOLD
MULTI

CHROMOSPHERE

BERKTHOLD

BERKTHOLD
DINOV 840

517.26 Application of Other Articles

- Revision clarifies the application of other code requirements with healthcare facilities
- **Life safety branch** of the EES must meet Article 700 requirements for emergency systems
- Aligns NEC requirements with NFPA 99



517.30 Coordination (EES Hospitals)

- Revision aligns with the performance requirements in NFPA 99
- Overcurrent protective devices must be coordinated for faults extending beyond 0.1 seconds
- Coordination term used to differentiate this requirement from other code sections which require selective coordination.

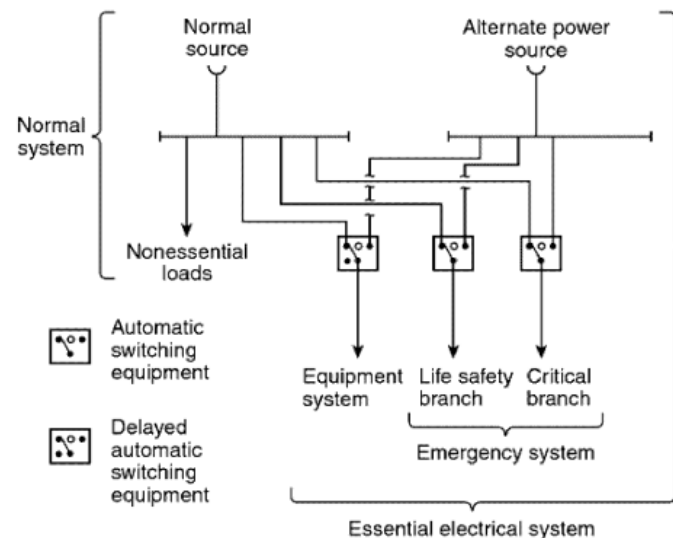

Article 625 EV Supply Equipment



Proposals add EV Supply Equipment requirements throughout the article

Electric Vehicle Supply Equipment System. A system of components that provide an ac output that is supplied to the vehicle for the purpose of providing input power to an on-board charger.

- 625.17 Cords and Cables added to cover the Power Supply Cords and Output Cable to the Electric Vehicle
- 625.41 Permits an Energy Management system to establish calculated load
- 625.44 Sets requirements for Cord and Plug Connected EV Supply Equipment

625.44(A) – (EVSE) Connections to 125-Volt, Single-Phase, 15- and 20-Ampere Receptacle Outlets

Electric Vehicle Supply Equipment Connections

- Supplied from 125 V receptacle outlets where rated 15 or 20 amperes, non-locking, 2-pole, 3-wire, grounding type

or

- Supplied at less than 50 V dc



625.44(B) – (EVSE) Connections to Other Receptacle Outlets

Receptacle Outlets must comply with all of the following:

- Rated 250 V maximum
- 50 amperes or less
- Non-locking, 2-pole, 3-wire, and 3-pole, 4-wire, grounding type
- EVSE fastened in place
- Supply cord limited to 6 ft length
- Located to avoid physical damage to the supply cord



All other EVSE (over 250 V) must be permanently wired and fastened in place

690.5(A) – Ground Fault Protection

Protection must ...

1. Be capable of detecting a ground-fault current in PV array dc current carrying conductors and components including any intentionally grounded conductors,
2. Interrupt the flow of fault current,
3. Provide an indication of the fault, and
4. Listed for PV ground fault protection



Similar revision to 690.35(C) for ungrounded PV systems

690.12 Rapid Shutdown

PV Systems in or on Buildings must provide a rapid shutdown function with that controls specific conductors as follows:

- Requirements for controlled conductors apply only to PV system conductors of more than 5 feet in length inside a building, or more than 10 feet from a PV array.
- Controlled conductors limited to no more than 30 volts and 240VA within 10 seconds of rapid shutdown initiation.
- Rapid shutdown initiation methods labeled in accordance with 690.56(B).
- Rapid shutdown equipment must be listed and identified



690.15(C) DC Combiner Disconnects

- Disconnect required for the dc output of dc combiners mounted on roofs of dwellings or other buildings
- Must be load break rated
- Located in the combiner or within 1.8 m (6 ft) of the combiner
- Remote control is permitted where the disconnect is also manually operable locally when control power is not available



690.17(A) Disconnect Type

PV disconnecting means ... one of the following devices:

- (1) An industrial control switch marked for use in PV systems.
- (2) A molded case circuit breaker marked for use in PV systems
- (3) A molded case switch marked for use in PV systems.
- (4) An enclosed switch marked for use in PV systems.
- (5) An open-type switch marked for use in PV systems.
- (6) A dc-rated molded case circuit breaker suitable for backfeed operation.
- (7) A dc-rated, molded case switch suitable for backfeed operation.
- (8) A dc-rated enclosed switch.
- (9) A dc-rated open-type switch.
- (10) A dc rated low voltage power circuit breaker.



695.1(B)(3) – Transfer Equipment

(3) Not Covered.

Transfer equipment upstream of the fire pump transfer switch(es)

Upstream transfer equipment can be located outside the fire pump room

Not Covered

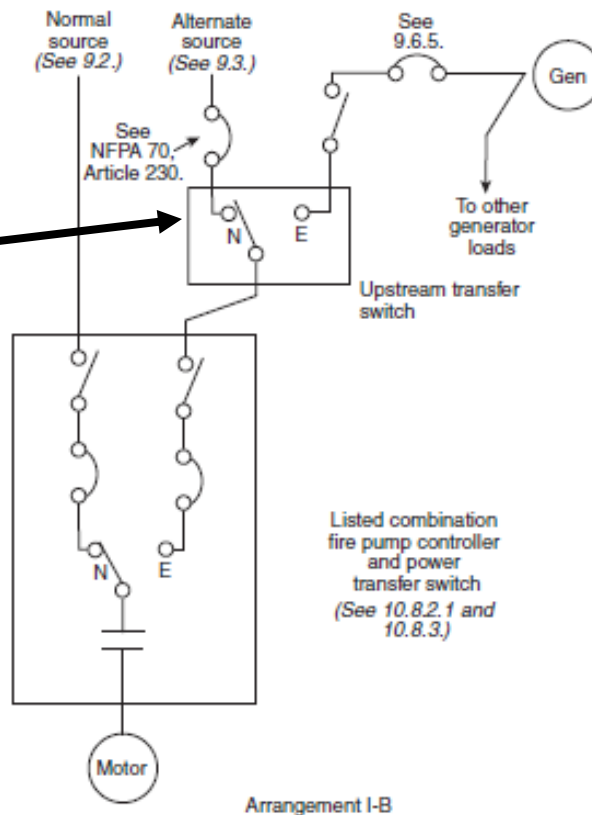

695.3(F) – Transfer of Power

Transfer of power to the fire pump controller between the individual source and one alternate source shall take place within the **pump room**.

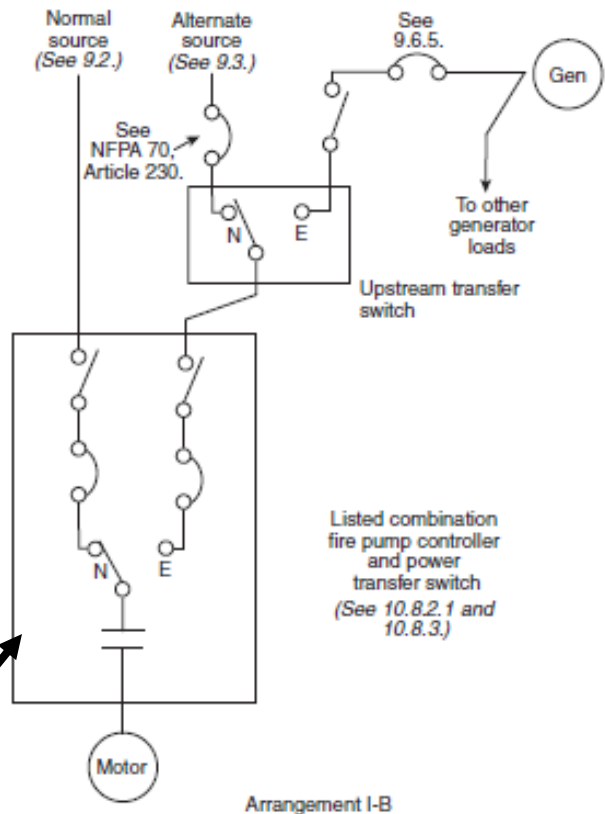

Fire Pump
Room Only

695.3(F)(2) – Overcurrent Device Selection

Instantaneous trip circuit breaker permitted in lieu of the overcurrent devices specified in 695.4(B)(2)(a)(1) **provided** it is part of a transfer switch assembly listed for fire pump service which complies with 695.4(B)(2)(a)(2).

700.8 – Surge Protection

Emergency systems are required to have surge protection in or on all

- Switchboards and
- Panelboards



700.10(B)(5) – Emergency System Wiring

(5) Wiring from an emergency source to supply any combination of emergency **and other loads** in accordance with (a), (b), (c) and (d).

- (a) Separate vertical switchboard sections, with or without a common bus, or individual disconnects mounted in separate enclosures **shall be used to separate emergency loads from all other loads.**
- (b) The common bus of separate sections of the **switchgear**, separate sections of the switchboard or the individual enclosures shall be permitted to be supplied by single or multiple feeders without overcurrent protection at the source.
- (c) Emergency circuits shall not originate from the same vertical **switchgear** section, vertical switchboard section, panelboard enclosure or individual disconnect enclosure as **other** circuits.
- (d) It shall be permissible to utilize single or multiple feeders to supply distribution equipment between an emergency source and the point where the emergency loads are **separated from all other loads.**

Exception to (5) (b). Overcurrent protection shall be permitted at the source or for the equipment, provided the overcurrent protection complies with the requirements of 700.27.

700.10(B)(5) – Emergency System Wiring

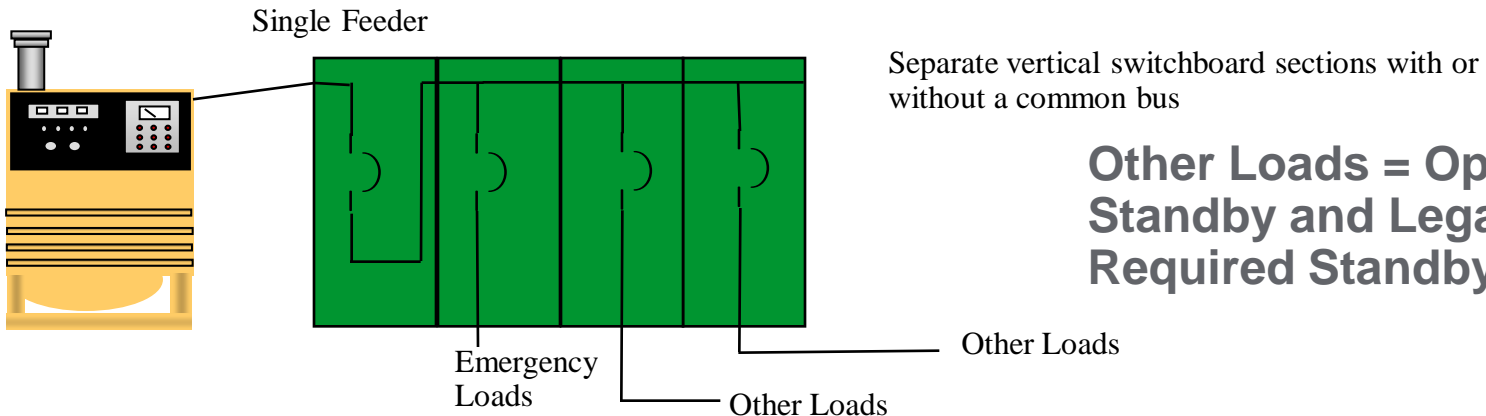
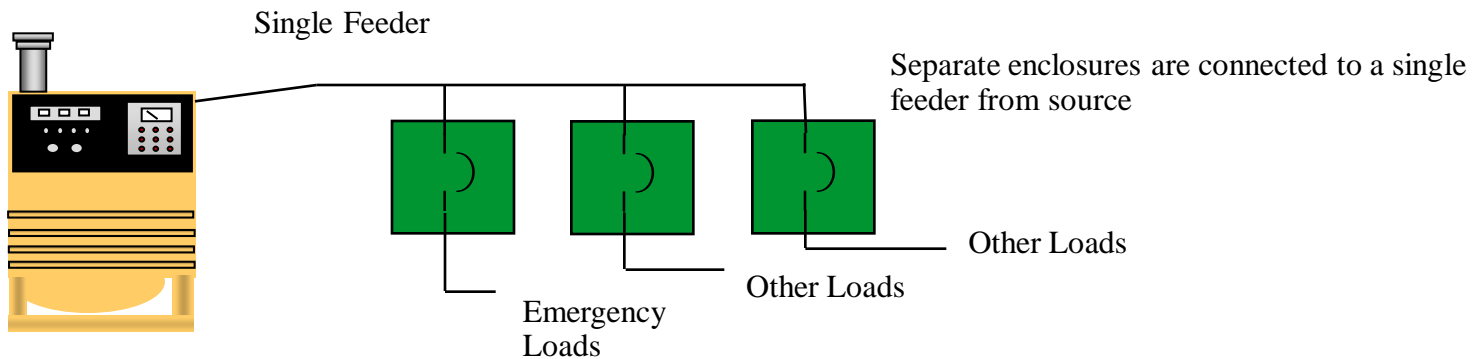
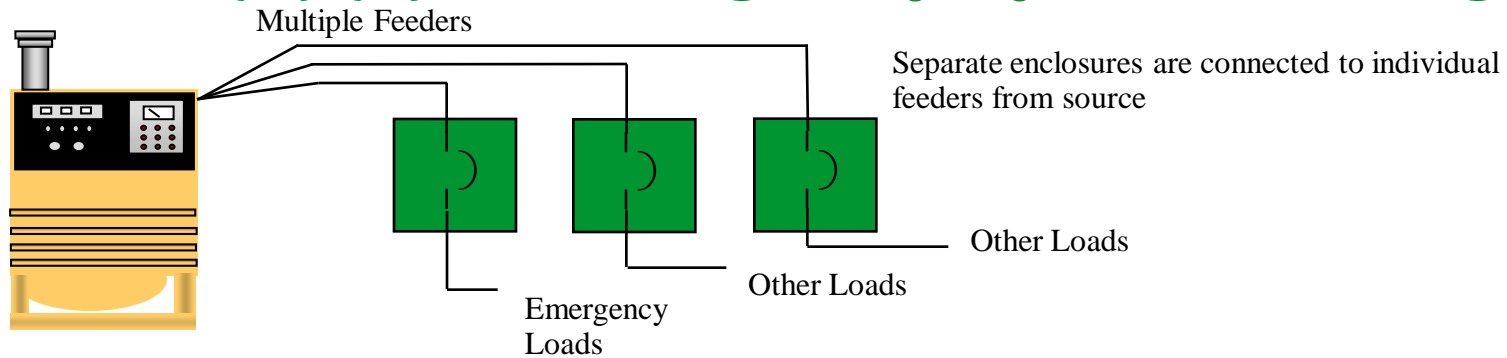

Other Loads = Optional Standby and Legally Required Standby

700.16 – Emergency Illumination

- Emergency illumination required in the area of the disconnecting means required by 225.31 and 230.70, as applicable, where the disconnecting means are installed indoors.
- Exception provided where an alternative means is provided to ensure emergency lighting illumination is maintained.



700.19 – Multiwire Branch Circuits

Branch circuits serving emergency lighting and power circuits must not be part of a multiwire branch circuit



700.24 – Directly Controlled Luminaires

- Listed for Use in Emergency Systems
- Applies to luminaires and external bypass controls where the luminaires are directly controlled and respond to external control to bypass normal control upon loss of normal power.

702.7(C) Power Inlet

Warning Sign

- Used for temporary portable generator connection
- Located near the inlet
- Communicates system type

WARNING:
**FOR CONNECTION OF A SEPARATELY
DERIVED
(BONDED NEUTRAL) SYSTEM ONLY**
or
WARNING:
**FOR CONNECTION OF A
NONSEPARATELY
DERIVED (FLOATING NEUTRAL)
SYSTEM ONLY**



702.12(A) – Outdoor Generator Sets

Permanently Installed Generators and Portable Generators Greater Than 15KW

- The generator disconnect can serve as the building or structure disconnect where all of the following apply:
 - Readily accessible
 - Meets generator disconnect requirements in 445.18
 - Located within sight
 - Power Inlets must include 702.7(C) sign indicating the system type
- Installations where a disconnect is provided at the building must meet the feeder disconnect requirements in 225.36



702.12(B) – Outdoor Generator Sets

Portable Generators Less Than 15KW

- Flanged inlet or other cord and plug type connections of small portable generators can serve as the building or structure disconnect
- Power inlet installations must include the 702.7(C) sign requirements indicating if the system is separately derived or non-separately derived



705.31 – Location of Overcurrent Protection

Interconnected Electric Power Production Sources

Overcurrent protection for the source conductors, connected to the supply side of the service disconnecting means in accordance with 705.12(A), must be located within (10 ft) of the point where the electric power production source conductors are connected to the service.



Exception permits overcurrent protection more than 10 ft from the point of connection where cable limiters or current limited circuit breakers for each ungrounded conductor are installed at the connection point to the service.

About the Instructor

● Chad Kennedy, P.E.

- Manager, Industry Standards at Schneider Electric
- Member NEC CMP 13
- Member of Technical Committee NFPA 99
- Member of UL, NEMA, and IEEE Technical Committees for Panelboards, Switchboards, Switches, and Switchgear
- Member of NFPA and NFPA Electrical Section
- IAEI Member
- Chair, NEMA Sharp Edges Task Force

